

DC Axial

Compact Fan, $\Phi 200$

DC轴流风机



Impeller: Plastic PA66+GF
shell: Metal aluminum sheet
Motor: DC brushless external rotor motor
Insulation: Class B
Approvals: CE;UL E306337
Operating Temperature: -20~+60°C

叶轮材质: 塑胶尼龙+玻纤
 外框材质: 金属铝合金
 电机类型: DC无刷外转子电机
 绝缘等级: Class B
 产品符合的认证: CE;UL E306337
 工作温度: -20~+60°C

技术参数 Specifications

Listed Model 产品型号	Rated Voltage 额定电压	Operating Voltage 工作电压	Rated Current 额定电流	Rated Power 额定功率	Rated Speed 额定转速	Air Flow 风量		Air Pressure 风压		Noise Level 噪音	Net Weight 重量
Part NO.	VDC	VDC	A	W	RPM	CFM	m ³ /h	mmH ₂ O	inH ₂ O	dBA	Kg
PF2420070HB2M	24	16~28	4.5	108.0	4,600	517.7	880	67.6	2.66	69.5	1.75
PF4820070HB2M	48	36~56	2.3	110.4	4,600	517.7	880	67.6	2.66	69.5	1.75

外形 Outline

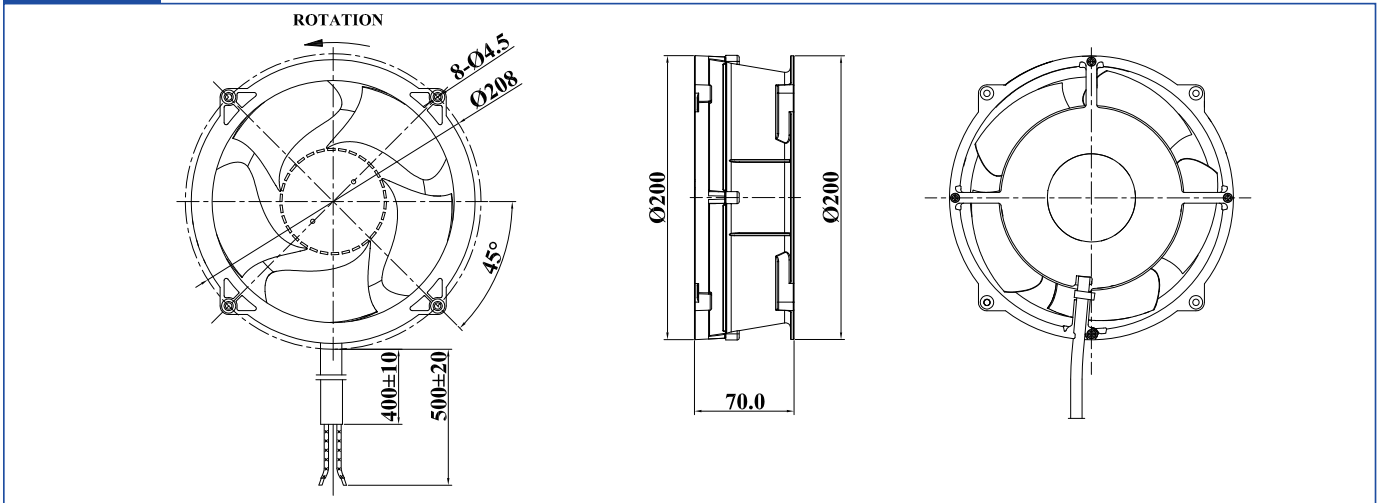

曲线 Curves

