

# DC Axial

Compact Fan,  $\Phi$  254

## DC轴流风机



**Impeller:** Plastic PBT+GF  
**shell:** Metal aluminum sheet  
**Motor:** DC brushless external rotor motor  
**Insulation:** Class B  
**Approvals:** UL E306337  
**Operating Temperature:** -20~+60°C

叶轮材质: 塑胶PBT+玻纤  
 外框材质: 金属铝合金  
 电机类型: DC无刷外转子电机  
 绝缘等级: Class B  
 产品符合的认证: UL E306337  
 工作温度: -20~+60°C

### 技术参数 Specifications

Listed Model 产品型号	Rated Voltage 额定电压	Operating Voltage 工作电压	Rated Current 额定电流	Rated Power 额定功率	Rated Speed 额定转速	Air Flow 风量		Air Pressure 风压		Noise Level 噪音	Net Weight 重量
Part NO.	VDC	VDC	A	W	RPM	CFM	m <sup>3</sup> /h	mmH <sub>2</sub> O	inH <sub>2</sub> O	dBA	Kg
PF2425489HB2M	24	16~28	2	48.0	2,000	725	1231	18	0.7	62	1.5
PF4825489HB2M	48	36~56	1.3	62.4	2,000	725	1231	18	0.7	62	1.5

### 外形 Outline

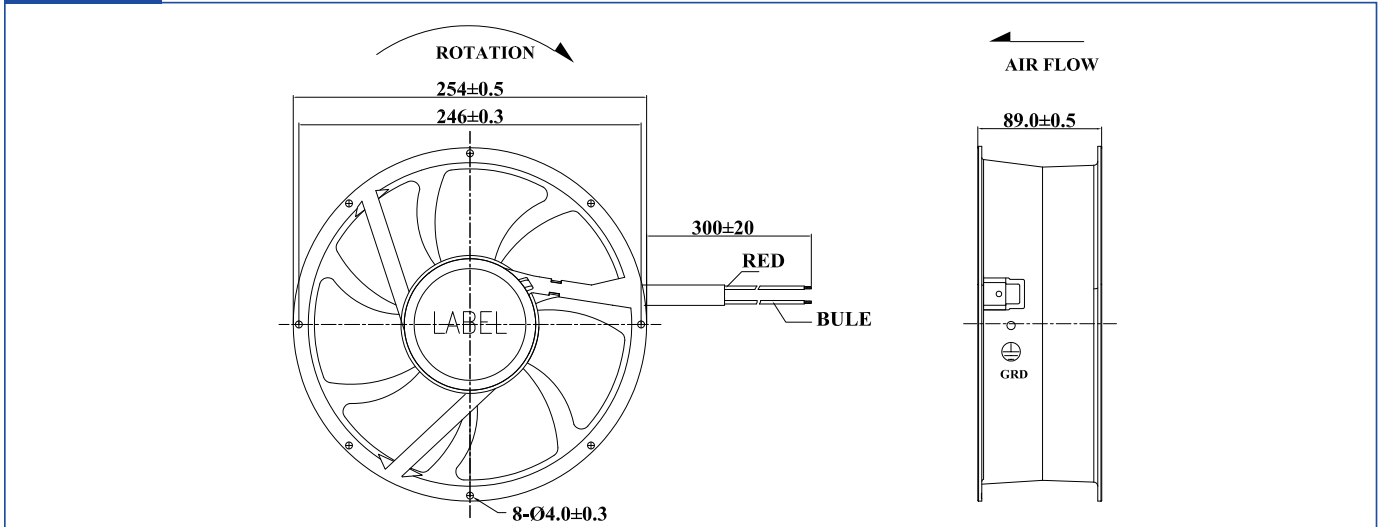

### 曲线 Curves

