

DC Axial

Compact Fan, $\Phi 280$

DC轴流风机



Impeller: Metal steel and coated in black
shell: Metal aluminum sheet
Motor: DC brushless external rotor motor
Insulation: Class B
Approvals: UL E306337
Operating Temperature: -20~+60°C

叶轮材质: 金属钢及表面烤黑漆
 外框材质: 金属铝合金
 电机类型: DC无刷外转子电机
 绝缘等级: Class B
 产品符合的认证: UL E306337
 工作温度: -20~+60°C

技术参数 Specifications

Listed Model 产品型号	Rated Voltage 额定电压	Operating Voltage 工作电压	Rated Current 额定电流	Rated Power 额定功率	Rated Speed 额定转速	Air Flow 风量		Air Pressure 风压		Noise Level 噪音	Net Weight 重量
Part NO.	VDC	VDC	A	W	RPM	CFM	m ³ /h	mmH ₂ O	inH ₂ O	dBA	Kg
PF2428080HB2M	24	16~28	5.2	124.8	2,750	1110.2	1886	25.36	1.00	68	2.5
PF4828080HB2M	48	36~56	2.6	124.8	2,750	1110.2	1886	25.36	1.00	68	2.5

外形 Outline

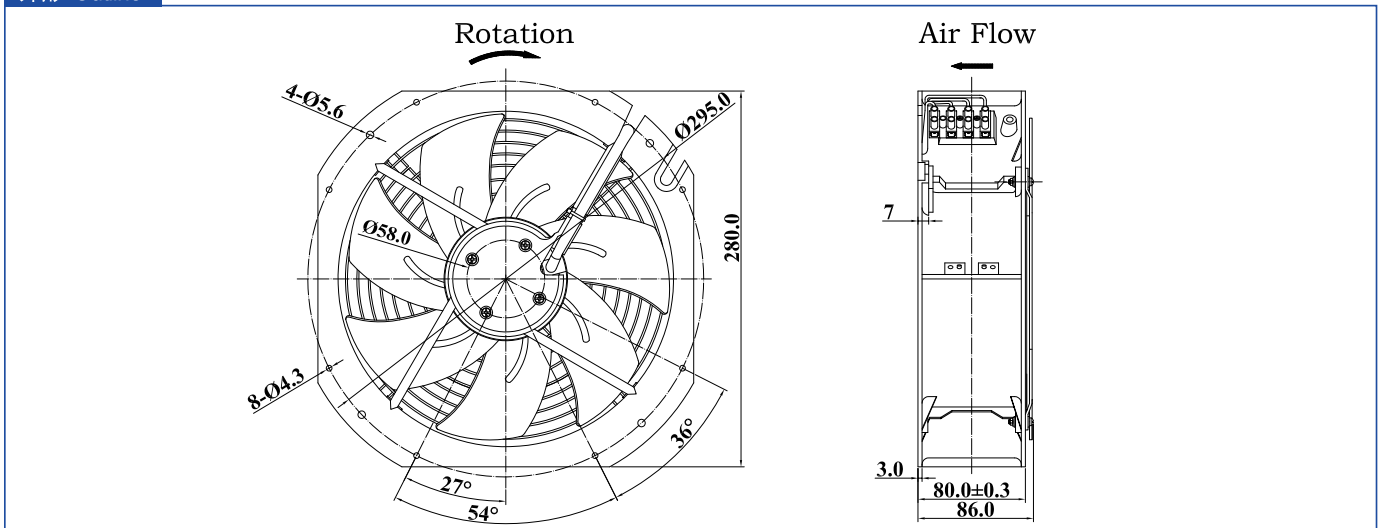

曲线 Curves

